

# DFA-R-ND SERIES

## Digital Force Gauge

The CHATILLON® DFA-R-ND Series uses REMOTE Series loadcells for the load measurement device. These gauges do not come with a loadcell. The REMOTE Series loadcell must be ordered separately. The DFA-R-ND with REMOTE loadcell has an accuracy of  $\pm 0.3\%$  of full scale. This gauge features RS232 serial data communications and an internal sampling rate of 10,000Hz. The DFA-R-ND Series is ideal for critical applications where capturing peak readings is required. Other features include the ability to store up to 1000 test readings in up to 99 different user-defined batches. The gauge features programmable high and low setpoints, pushbutton calibration and an analogue output for graphing the force curve. An easy-to-use operator interface lets users perform gauge configuration using the keypad and intelligent prompts and menus from the instrument's high resolution LCD display. Gauges come with accessories, battery charger and protective carrying case.

### FEATURES

- Requires REMOTE Series Loadcells
  - Capacities up to 10,000 lbf (50 kN)
- Simple Pushbutton Operation
- Rugged All-Metal Housing
- 10,000Hz Sampling Rate
- Memory: 1000 Readings in 99 Batches
- RS232 Serial Data Communications
- Overload Capacity- 110% of Rated Capacity
- Hand-held or Test Stand Applications

### SPECIFICATIONS

Accuracy:	$\pm 0.3\%$ of Full Scale $\pm 1$ LSC
Selectable Units:	oz, g, lb, kg, N
Overload Capacity:	110% of rated capacity
Display:	LCD, 4-1/2 characters
Sampling:	10,000Hz
Outputs:	RS232, Mitutoyo
Power:	AC Adapter, NiCd Battery Pack
Accessories:	Carrying Case, Attachments Extension Rod, Battery Charger
Weight:	2 lbs (0.9 kg)
Warranty:	1 Years



SPECIFICATION  
SS-FM-3314-1101  
November 2001



Pharmaceuticals



Electronics



Medical Device

### INTERNET

[www.force-gauge.net](http://www.force-gauge.net)

AMETEK and CHATILLON are registered trademarks of AMETEK, Inc.  
LLOYD INSTRUMENTS is a trademark of AMETEK, Inc.

Copyright 2000, by AMETEK, Inc.  
Printed in U.S.A

**Chatillon**   
A registered trademark of AMETEK Inc.

# EASY-TO-USE INTERFACE

DFA Series Gauges put a powerful INTEL® microprocessor in your palm, allowing you to collect up to 1,000 reviewable data readings in memory, then download them via the gauge's RS-232 serial data communications. You follow a simple hierarchy of menu displays to filter data and configure gauge settings, including data transmission. You may even calibrate and test the gauge automatically. The gauges modular architecture allows you to evolve as technology evolves. Using a personal computer, you may download new features and functionality as they are introduced.

**FUNCTION** keys at each of the four corners of display work with menus to select options, as well as to go to "downstream" menus.

**NORMAL DISPLAY** starts up after the gauge is turned on. F1 key toggles between the standard force measurement setting or settings which capture peak tension or compression force. Indicators below shows portion of battery charge remaining, time remaining until auto shutdown, and whether the high or low force levels are being exceeded. F4 key allows you to toggle display reading between pounds, kilograms, and Newtons, or ounces, grams, and Newtons.

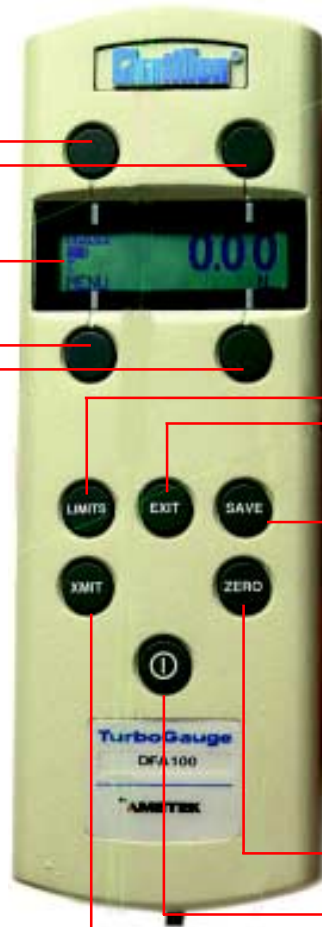

TRANSMIT... BUZZER...  
HI LIM... LO LIM...

Function Key F1

Function Key F2

Function Key F3

Function Key F4

**LIMITS** button allows you to transmit signals to control test stand motion (F1). Key F2 allows you to activate or deactivate the limits buzzer, which sounds when the force exceeds the limits set. Both high and low limits may be set (F3, F4), allowing you to stop test stand motion at predetermined loads or to cycle between set points (CHATILLON® Model TCD test stands only). Limits guard against load cell damage.

**EXIT** button moves you back to prior screen in menu.

NORM... 0.1256 LB  
MENU...

NORM... BATCH 01 #001 NB...  
REVIEW... 00% LB

**SAVE** button takes you to "Data Save" mode, where you can save a reading to current batch or open a new batch (F2). Once data is saved, the F3 key allows you to review your saved data. The F4 key lets you change reading units to lb, Kg, N, oz and g. Up to 1,000 different time-stamped readings may be saved, in as many as 99 batches.

**ZERO** button returns current data reading in window to "0".

**ON/OFF** key saves all gauge setting each time the gauge is turned off.

**XMIT** button transmits current reading or batch via the gauge's RS-232 port or sends it to a Mitutoyo data collector.

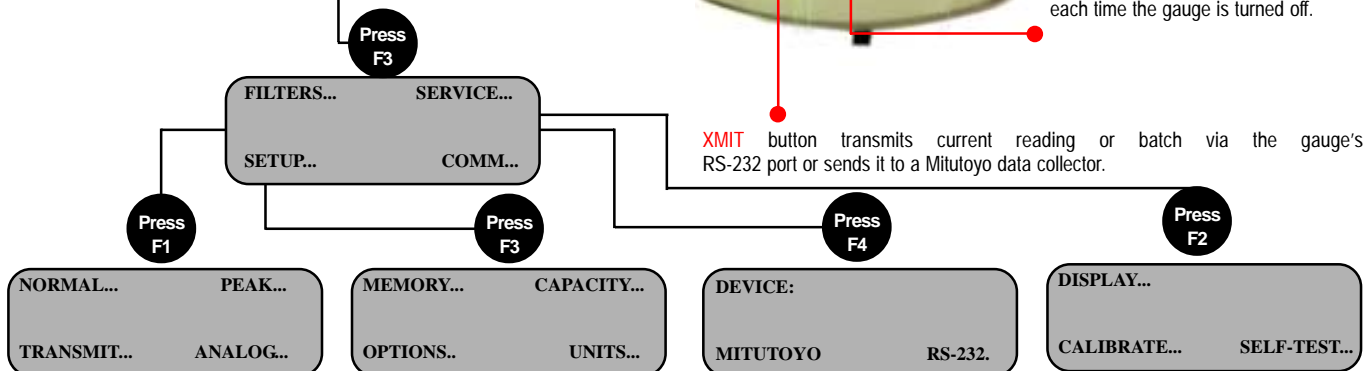

**FILTERS MENU** lets you set the sampling rate for four different streams of data -- normal force reading, peak force reading, RS-232 transmission and analog output. (See table on opposite page.) With each stream, you can regulate and change the data rate to match your needs. The resulting data flow is averaged from all of the data points taken at the the gauge's inherent sampling rate of 10,000 samples per second. The result is a distillation of data that still reflects the extraordinarily high collection rate of the gauge.

EXAMPLE SUBSCREEN (for peak filter rate)

PEAK: INCREASE  
0.1256

**SETUP MENU** allows you to set the time and date under "Memory" (F1) and to activate various options (F3), such as auto shutdown, sign, and print options. The capacity menu (F2) is only available for the Remote Non-Dedicated Gauges and allows the gauge to be set for proper maximum load. The Units menu (F4) allows you to "lock in" the desired units of measurement, keeping them from being changed accidentally.

**COMMUNICATIONS MENU** is for selecting Mitutoyo or RS-232 output. This menu lets you quickly and easily set the parameters for RS-232 communications, such as from the gauge to a digital test stand or to a remote computer. Settings include stop bit length, baud rate, and parity, as well as whether units are to be included with the transmission.

EXAMPLE SUBSCREEN (for baud rate):

BAUD INCREASE  
0.1256  
OK 19200 DECREASE

**SERVICE MENU** allows you to adjust the display contrast (F1) lighter or darker for display angle and light conditions. You can also calibrate the gauge (F3) using standard weights, as well as troubleshoot gauge problems with a self-test setting (F4). The latter is a highly useful tool for AMETEK service technicians, allowing them to work with you over the telephone to check out your gauge. It includes tests for proper keypad function and possible load cell damage.

## ORDERING INFORMATION

Model	Capacity x Resolution
DFA-R-ND	Determined by REMOTE Series Loadcell

Note: Please add "-220V" after the Model number if you require 220V power and operation.



## ORDERING INFORMATION

REMOTE Series loadcells are used exclusively on CHATILLON® DFGS-R-ND and DFA-R-ND Series digital force gauges. They provide users with a flexible way to use multiple load measurement capacities on a single gauge body. Users can easily change loadcells to capacities from 2 lbf (10 N) to 10,000 lbf (50 kN). These loadcells feature a 6-pin connector which plugs directly into the force gauge. The 24-inch (610mm) shielded, coiled cable, retracts fully to 96 inches (2440mm).

## SPECIFICATIONS

Rated Output:	3.00 ±0.25% mV/V
Maximum Load:	200% of rated output
Nonlinearity:	±0.10% of rated output
Hysteresis:	0.05% of rated output
Loadcell Deflection*:	0.005 to 0.020 ±0.002 F.S.

\* Dependent of loadcell capacity

Dimensional drawing for REMOTE Series with capacities over 10 lbf (50 N). Dimensions are show in inches and (mm).

Capacity	Part No.	A	B	C	D	E
2 lbf (10 N)	REMOTE-2	-	-	-	-	-
10 lbf (50 N)	REMOTE-10	-	-	-	-	-
50 lbf (200 N)	REMOTE-50	2.5 (63.5)	2.0 (50.8)	0.63 (16.0)	0.3 (7.6)	1.0 (25.4)
100 lbf (500 N)	REMOTE-100	2.5 (63.5)	2.0 (50.8)	0.63 (16.0)	0.3 (7.6)	1.0 (25.4)
200 lbf (1 kN)	REMOTE-200	2.5 (63.5)	2.0 (50.8)	0.63 (16.0)	0.3 (7.6)	1.0 (25.4)
500 lbf (2.5 kN)	REMOTE-500	3.0 (76.2)	2.0 (50.8)	1.0 (25.4)	0.5 (12.7)	1.0 (25.4)
1000 lbf (5 kN)	REMOTE-1000	3.0 (76.2)	2.0 (50.8)	1.0 (25.4)	0.5 (12.7)	1.0 (25.4)
2000 lbf (10 kN)	REMOTE-2000	3.0 (76.2)	2.0 (50.8)	1.0 (25.4)	0.5 (12.7)	1.0 (25.4)
5000 lbf (20 kN)	REMOTE-5000	4.25 (107.9)	3.0 (76.2)	1.0 (25.4)	0.5 (12.7)	1.5 (38.1)
10,000 lbf (50 kN)	REMOTE-10000	4.75 (120.7)	3.5 (88.9)	1.0 (25.4)	0.5 (12.7)	1.75 (44.5)

REMOTE Series loadcells are exclusively used with DFGS-R-ND and DFA-R-ND Series digital force gauges. Loadcells must be ordered separately.

## DIMENSIONS

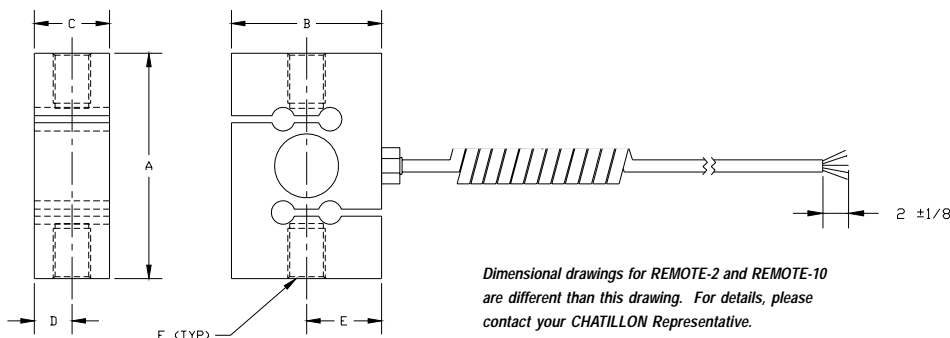

Dimensional drawings for REMOTE-2 and REMOTE-10 are different than this drawing. For details, please contact your CHATILLON Representative.

## GAUGE ADAPTERS

Adapters	Capacity	Availability	Part No.	Notes
Chisel Point, #10-32	100 lbf (500 N)	Optional	SPK-FMG-008A	
Chisel Point, 5/16-18	500 lbf (2.5 kN)	Optional	SPK-FMG-008B	
Point Adapter, #10-32	100 lbf (500 N)	Optional	SPK-FMG-009A	
Point Adapter, 5/16-18	500 lbf (2.5 kN)	Optional	SPK-FMG-009B	
Notch Adapter, #10-32	100 lbf (500 N)	Optional	SPK-FMG-010A	
Notch Adapter, 5/16-18	100 lbf (500 N)	Optional	NC000721	5/8 inch (15mm) notch size
Notch Adapter, 5/16-18	500 lbf (2.5 kN)	Optional	SPK-FMG-010B	
Notch Adapter, 5/16-18	500 lbf (2.5 kN)	Optional	NC000725	1.0-inch (25mm) notch size
Flat Adapter, #10-32	100 lbf (500 N)	Optional	SPK-FMG-011A	
Flat Adapter, 5/16-18	500 lbf (2.5 kN)	Optional	SPK-FMG-011B	
Flat Disc, 5/16-18		Optional	NC000751-1	3.25 x 0.5 inch (83 x 12mm)
Flat Disc, 5/16-18		Optional	NC000751-2	3.25 x 0.25 inch (83 x 6mm)
Rectangular Fixture, 5/16-18		Optional	NC000730-1	3.5 inch (89mm) diameter
Rectangular Fixture, 5/16-18		Optional	NC000738-1	0.75 inch (19mm) diameter
Hook, #10-32	50 lbf (225 N)	Optional	SPK-FMG-012A	
Hook, #10-32	100 lbf (500 N)	Optional	SPK-FMG-012B	
Hook, Swivel, #10-32	20 lbf (112 N)	Optional	ML3867	
Hook, Swivel, #10-32	100 lbf (500 N)	Optional	ML3850	
Hook, 5/16-18	500 lbf (2.5 kN)	Optional	SPK-FMG-012C	
Hook, Swivel, 5/16-18	500 lbf (2.5 kN)	Optional	ML3868	
Hook, with Clasp, 5/16-18	500 lbf (2.5 kN)	Optional	NC002500	
Extension Rod, #10-32		Optional	SPK-FMG-013A	
Extension Rod, 5/16-18		Optional	SPK-FMG-013B	
Adapter, #10-32F to 5/16-18M		Optional	P-10020	Required for 5/16 Fixtures
Coupling, #10-32 to 6M		Optional	NC002652	For metric probes/grips



Chisel Point



Point Adapter



Notch Adapter



Flat Adapter



Hook

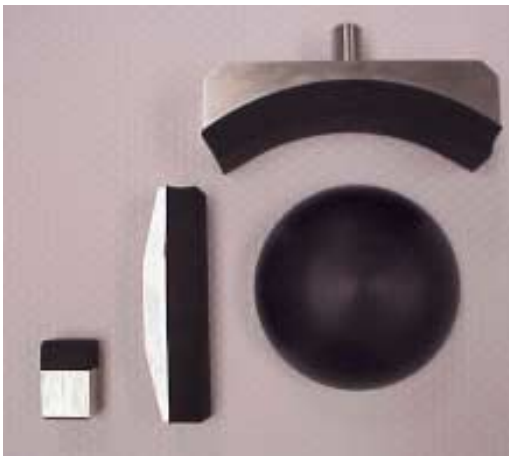

### Specialty Fixtures for Ergonomics

The DFGS Series can be equipped with specialty fixture for ergonomic testing, muscle strength testing and job task analysis applications. Shown are various fixtures including rectangular fixtures and flat discs.

## STANDARD ACCESSORIES

Accessories	Availability	Part No.	Notes
Protective Carrying Case	Standard	SPK-FMG-073	
Battery Charger, 115V	Standard	SPK-FMG-069A	Standard with 115V models
Battery Charger, 220V	Standard	SPK-FMG-069B	Standard with 220V models
Hex Key, 7/64-inch	Standard	SPK-FMG-015	
Operators' Manual	Standard	SPK-DFA-081	
Flash Memory Upgrade Kit	Optional	E80-715	

## TEST STAND GAUGE ADAPTER KITS

Test Stand Type	Availability	Part No.	Notes
LTS Series	Optional	NC000300	
LTC Series	Optional	NC000300	
HTC Series	Optional	NC000225	
TT Tester	N/A	N/A	Not Compatible
LTCM-6 Series	Optional	NC000300	
TCM201 Series	Optional	NC000300	
TCD200 Series	Optional	NC000300	
LFPLUS Series	Optional	SPK/LFM/0001	
LRX Series	N/A	N/A	Not Compatible
LRXPLUS Series	N/A	N/A	Not Compatible
LR5KPLUS Series	N/A	N/A	Not Compatible

## GAUGE APPLICATION SOFTWARE

Software	Availability	Part No.	Notes
NEXYGEN GAUGE Software (Single User)	Optional	40/0739	Single User License
NEXYGEN GAUGE Software (5 Pack)	Optional	40/0739/5	5 User License
NEXYGEN GAUGE Software (10 Pack)	Optional	40/0739/10	10 User License

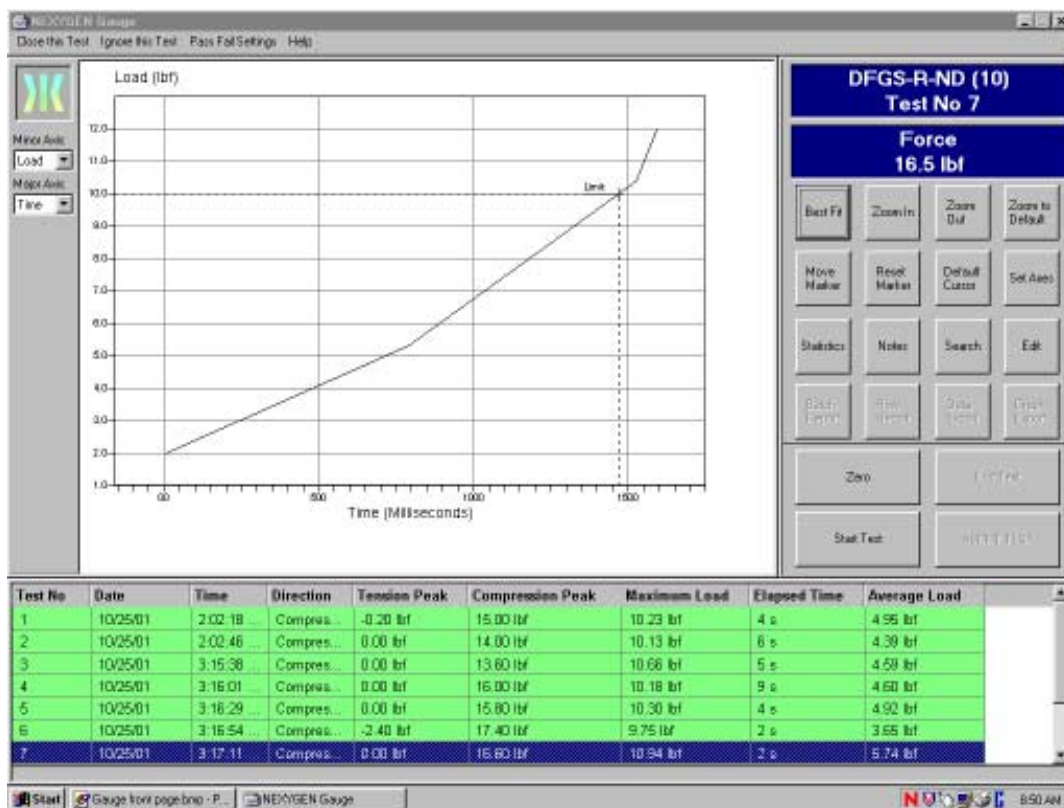

NEXYGEN GAUGE software allows you to collect load measurements from your force gauge and display and analyze results information in both tabular and graphical formats. You can automatically create reports in WORD or EXCEL and define pass/fail conditions. You can change the size of your graph, overlay graphs, add notations, etc.

## INTERFACE CABLES

Interface Cables	Availability	Part No.	Notes
Personal Computer, 25-pin D, 6ft (2m)	Optional	NC000652	
Personal Computer, 25-pin D, 10ft (3m)	Optional	NC000652-1	
Personal Computer, 25-pin D, 20ft (7m)	Optional	NC000652-3	
Personal Computer, 9-pin D, 6ft (2m)	Optional	NC000850-1	Require when using NEXYGEN
Personal Computer, 9-pin D, 10ft (3m)	Optional	NC000850-2	Require when using NEXYGEN
MITUTOYO, 10-pin	Optional	NC000654	
MITUTOYO, RS232	Optional	NC000697	
TCM201, 9-pin D	Optional	ENC0125	
TCD200, 9-pin D	Optional	NC000647	

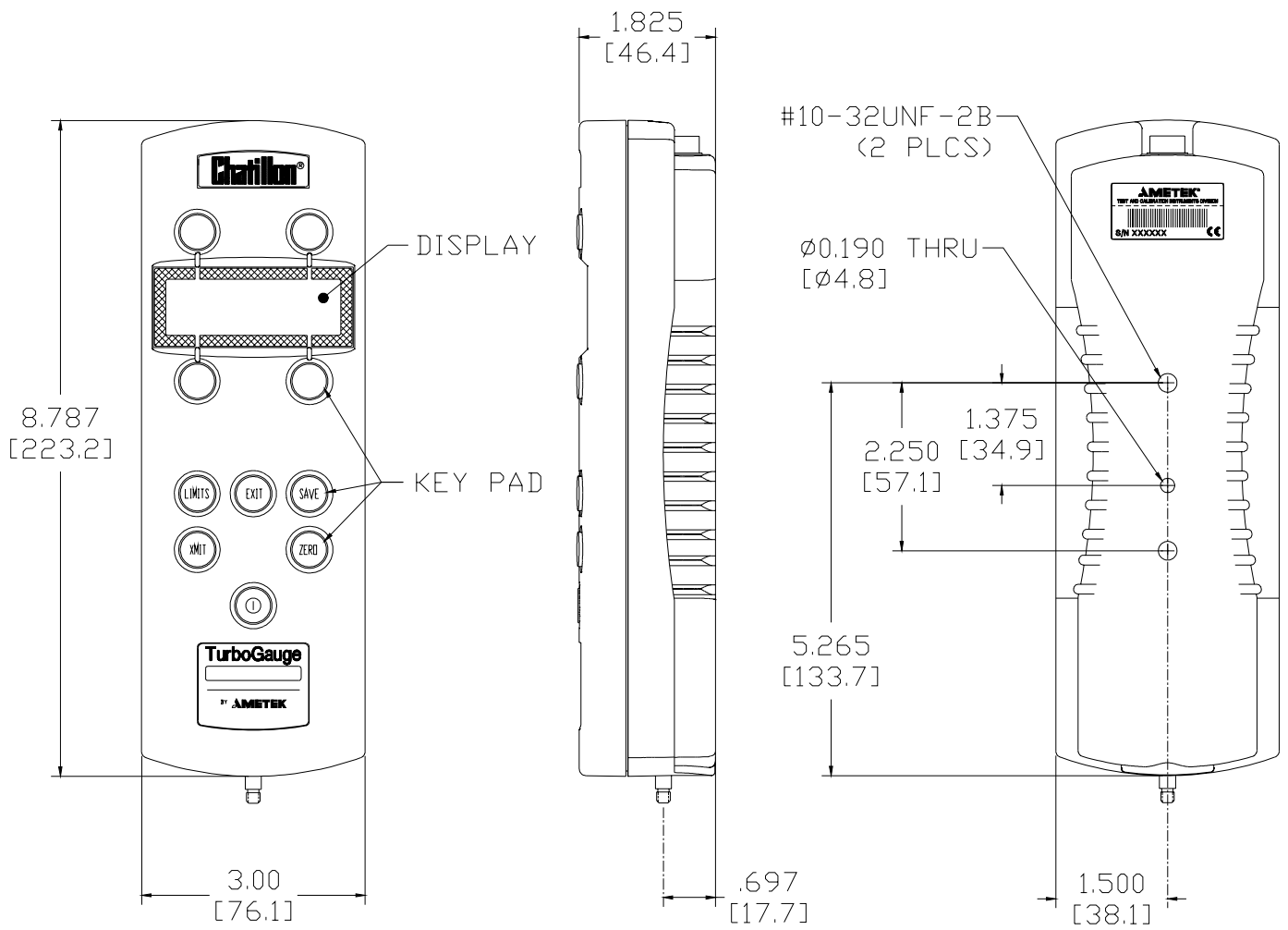

E96-188

**AMETEK**

Itin Scale Co., Inc.  
 431 Avenue U  
 Brooklyn, NY 11223  
 PHONE: 718-336-5900  
 FAX: 718-627-1313  
 EMAIL: sales@itinscales.com  
 www.itinscales.com