

MT150 Series Mechanical Tester

The MT150 Series mechanical test stand is an easy-to-use solution for force measurement applications up to 150 lbf (660N) capacities. The test stand may be equipped with a quick-action lever or precision handwheel for controlling crosshead speed and travel. The MT150 test stand can be bench mounted, wall mounted or positioned horizontally. Vertical clearances are available from 750mm (29.5 inch) up to 1500mm (60 inch). Standard stroke is 6 inches (150 mm), although longer strokes can be accommodated as a special order.

The MT150 Series features an innovative design that maximizes working space and simplifies operation and maintenance. The single column design with 150mm (6 in) throat is ideal for large specimens. The removable platen is designed to accommodate metric and imperial threaded fixtures. Special gauge adapter make gauge alignment automatic. Options include a digital travel indicator, capable of displaying travel up to 0.01mm (0.0005 inch) and column ruler which is graduated in millimeters and inches.

The MT150 Series includes hook, compression plate, adapters and gauge mounting hardware.

FEATURES

- Large Working Area
 - Adjustable Platens Maximize Stroke
 - 150mm (6 in) Throat for Large Specimens
 - Universal Fixturing (Metric or Imperial)
 - 150mm (6 in) Full Crosshead Travel
- Modular Design
 - Bench, Horizontal or Wall Mounted
 - Lever or Handwheel Operation
 - Multiple Travel Lengths
 - Gauge Adapters
 - Lightweight and Portable
 - Simple Single Column Design
 - Kits for Field Modifications

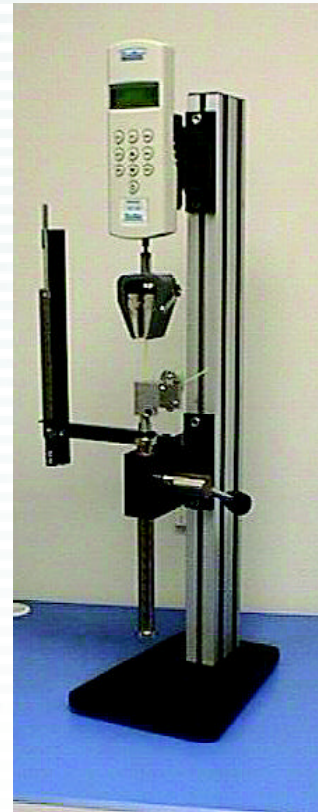

MT150L
Lever Actuated Tester with optional Ruler
Assembly. Shown with optional DFT
Force Gauge. Order gauge separately.

SPECIFICATION
SS-FM-3125-0603
June 2003

SPECIFICATIONS

Capacity:	150 lbf (660 N)
Loading Method:	Quick-Action Lever or Handwheel
Travel Rates:	
Lever	75mm (3 in) per Revolution
Handwheel	12mm (0.5 in) per Revolution
Column Height:	
Standard	750mm (29.5 inch)
Extended	1000mm (39.4 inch)
Ultra	1500mm (59 inch)
Maximum Stroke:	150mm (6 in) *Longer Strokes available upon request
Weight:	Approx. 20 lbs (9 kg)

AMETEK and CHATILLON are registered trademarks of AMETEK, Inc.
LLOYD INSTRUMENTS is a trademark of AMETEK, Inc.

Copyright 2003, by AMETEK, Inc.
Printed in U.S.A

Chatillon 
A registered trademark of AMETEK Inc.

ORDERING INFORMATION

Order No. Description

MT150L CHATILLON MT Series Mechanical Tester, Lever Actuated
 MT150H CHATILLON MT Series Mechanical Tester, Handwheel Actuated

Column Height - 7th Character

- S Standard, 750 mm (29.5 in)
- E Extended, 1000mm (39.4 in)
- U Ultra, 1500 mm (60 in)

Force Gauge Mounting Kit - 8th Character

- 1 DPP, LG, DFGS, DFA Series Force Gauges
- 2 DPPH, DFIS Series Force Gauges
- 3 DFM Series Force Gauge
- 4 DFT Series Force Gauge
- X Not Required

Mounting Style - 9th Character

- B Bench, Vertical Mounting
- H Bench, Horizontal and Wall Mounting

Options - 10th Character

- 1 Digital Travel Indicator
- 2 Ruler Assembly (Imperial/Metric Graduations)
- X Not Required

Sample Order Number

CHATILLON MT150 Series (150 lbf, 660N), standard 750mm (29.5 in) travel with LG Series mounting kit. Vertical bench mounting style with lever actuator. Optional digital travel indicator supplied.

MT150L S 1 B 1
 (MT150LS5B1)

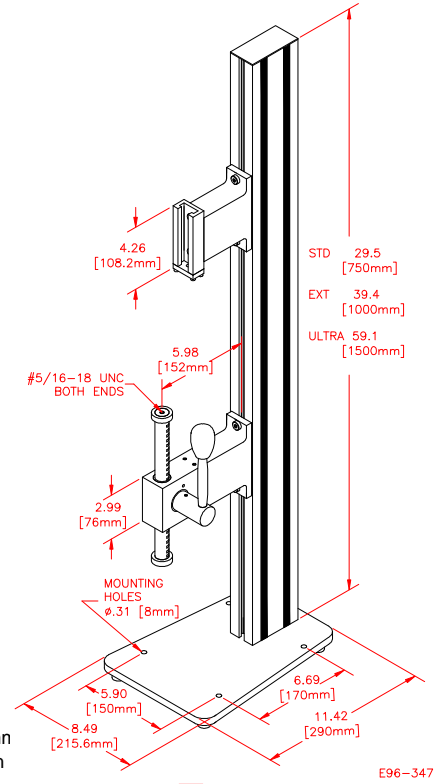

STANDARD ACCESSORIES

Order No.	Description
NC002660	User's Manual
NC000714	Hex Key, 6mm
SPK-FMG-012B	Hook, Stationary
17012	Platen, 3-inch diameter
NC002686	Set Screw, 5/16-18 x 1 inch
P-10020	Adapter, 5/16-18 to #10-32
13048	Coupling, 1/4-28 to 5/16-18
ADT/0115	Eye End Adapter, 5/8-inch
3157	Set Screw, #10-32 x 3/4-inch

OPTIONAL ACCESSORIES

Order No.	Description
SPK-MT-Digital	Digital Travel Indicator (May be ordered as part of stand)
SPK-MT-Ruler	Ruler Assembly (May be ordered as part of stand)
SPK-MT-0001	Gauge Mounting Kit, DPP, LG, DFGS, DFA Force Gauges
SPK-MT-0002	Gauge Mounting Kit, DPPH, DFIS Force Gauges
SPK-MT-0003	Gauge Mounting Kit, DFM Force Gauge
SPK-MT-0004	Gauge Mounting Kit, DFT Force Gauge
SPK-MT-0005	Gauge Mounting Kit, DG Force Gauge
SPK-MT-REMOTE	Gauge Mounting Kit, REMOTE Series Loadcells
SPK-MT-Wall-Horz	Wall/Horizontal Mounting Kit Assembly
SPK-MT-L150	Lever Actuator Assembly Module
SPK-MT-H150	Handwheel Actuator Assembly Module

Itin Scale Co., Inc.
 431 Avenue U
 Brooklyn, NY 11223
 PHONE: 718-336-5900
 FAX: 718-627-1313
 EMAIL: sales@itinscales.com
 www.itinscales.com